

# SLF - Street Lighting Cut Out



## SLF AS/NZ

### Specification

- Single Pole isolation
- Single fuse, 25A maximum rating
- Designed and tested in accordance with BS7654
- AS/NZS 3000 removable MEN link in dedicated terminals
- Terminals for loop-in, loop-out supply cable
- Terminal blocks accept up to 25mm<sup>2</sup> conductors
- Accepts fuse links to BS88 Part 1, AC tag type
- IP22 rating

### Features

- Cam operated lever for easy and safe fuse disconnection
- Compact product suitable for column bases 115mm or larger
- PA6 glass filled thermoplastic fuse carrier and base with interlocking covers
- Electro-tin plated terminal blocks and clips
- Terminal blocks equipped with serrated bores to aid cable retention with 3mm pinching screws
- Terminal blocks and contact clips retained by Torx security screws
- Fully shielded test probe access
- Clearly legible embossed terminal markings
- Integral gland plate with cable entry via two 20mm diameter PVC conical grommets
- Angle upper cable exit assists drip arrest
- Pre-loaded PX2 Pozidrive corrosion resistant fixing screws to attach to backboard
- Captive cover screws suitable for Pozidrive or slotted fixing
- Separate DNO and Local Authority seal provision
- Fully recyclable plastic and metallic parts

# SLF - Street Lighting Cut Out

## SLF AS/NZ

### Construction

- Body and fuse carrier PA6
- Red incoming cable cover ABS
- Incoming/outgoing terminals electro-tin plated brass
- Contact clips electro-tin plated phosphor bronze
- Incoming cable grommets soft PVC
- Terminal screws brass 3mm slotted
- Backboard fixing screws bright zinc passivated steel

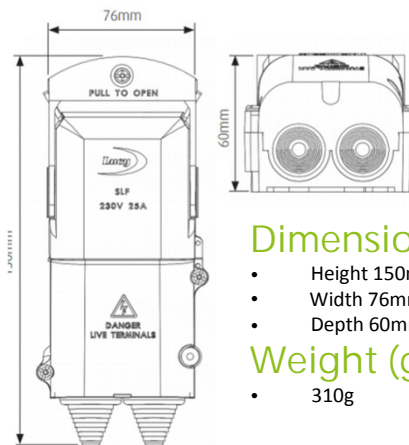

### Dimensions

- Height 150mm
- Width 76mm
- Depth 60mm

### Weight (grams)

- 310g

### Performance

- Rated operational voltage 230VAC 50/60Hz
- Rated continuous current 25A
- Maximum environmental pollution Degree 3
- Environmental conditions -25 to +40 Celsius
- IP rating IP22
- Recommended terminal torque setting 2.25Nm

### Alternative Options

- Titan 3TT version available which caters for larger cable sizes, 2 outgoing fuses, etc.

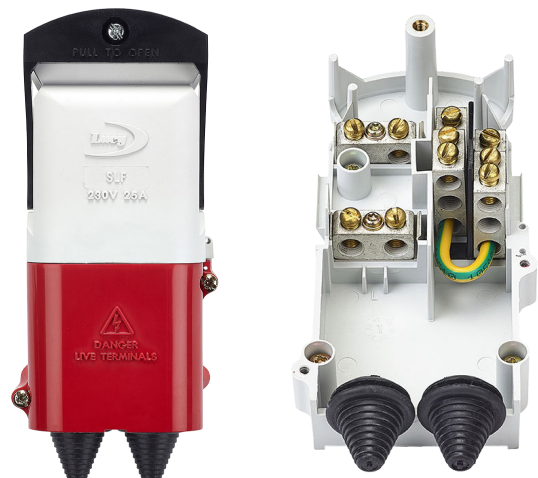

Part code	Description
THM0068827	SLF 25A SLCO (CNE) 3TTN 3TTE-D06-LINK supplied with 6A fuse fitted

Note: The equipment described on this data sheet must be installed by suitably trained and qualified personnel

Please contact our sales office for further details

**MI SYSTEMS**

Unit 3, 2 Alfred Street,  
Onehunga, Auckland,  
1061, New Zealand

Tel+64 (09) 622 1111  
sales@misystems.co.nz  
www.misystems.co.nz

Lucy Zodion Ltd,  
Station Road,  
Sowerby Bridge,  
HX6 3AF, United Kingdom

**Lucy Zodion**

Tel +44 (0)1422 317337  
Fax+44 (0)1422 836717  
sales@lucyzodion.com  
www.lucyzodion.com